

SPECIFICATIONS FOR T28 SERIES

WHITE LED

Model: 2835

Part No: T28xxx21C-Rxxxxx

Features:

- * Top view white LED
- * Thermally Enhanced Package Design
- * High luminous flux output
- * High current capability
- * Compact Package Size
- * Wide viewing angle
- * Pb-free Reflow Soldering Application
- * The product itself will remain within RoHS compliant version



Applications

- * Interior lighting
- * Retrofits (replacement)
- * General lighting
- * Architectural / Decorative lighting

Part Numbering System

T -

X1 X2 X3 X4 X5 X6 X7 X8 X9 X10

Item Number Code	Description	Content
X1	Type code	1S:1616; 1A:1919; 20:2016; 3B:3014; 28:2835 34:3020; 3C:3030; 5C:5050; 7C:7070; 1D:100100; 19: Ceramic 3535; 15: Ceramic 5050; 11: Ceramic 1616.
X2	CCT code	2700K:27;3000K:30;4000K:40;5000K:50;5700K:57;6500K:65; RE:Red;GR:Green;BL:Blue;YE:Yellow;PA:PC Amber.
X3	Color Rendering	Ra70:7; Ra80:8; Ra90:9; Ra85:A; Ra75:B; Ra95:C.
X4	No. of serial chip	1-Z.
X5	No. of parallel chip	1-Z.
X6	Component code	A-Z.
X7	Color Code	M:ANSI; F:ERP; R:85°C ANSI; T:105°C ANSI; B:Backlighting; Q:Others;
X8	Internal code1	\
X9	Internal code2	\
X10	Spare code	\

Electro Optical Characteristics, IF =150mA

CCT	Color Rendering	Luminous Flux	
		Tj=25°C	
	Min.	Typ.	Min.
2700K	70	135	125
	80	128	120
	90	106	100
3000K	70	142	135
	80	135	125
	90	112	105
4000K	70	150	140
	80	142	135
	90	117	110
5000K	70	150	140
	80	142	135
	90	117	110
5700K	70	150	140
	80	142	135
	90	117	110
6500K	70	150	140
	80	142	135
	90	117	110

* Tolerance of measurements of the Luminous Flux is $\pm 7\%$.

* Ra measurement tolerance is ± 2 .

* Correlated Color Temperature is derived from the CIE 1931 Chromaticity diagram.

Absolute Maximum Ratings at Tj=25°C

Item	Symbol	Absolute Maximum Rating	Unit
Forward current	I _F	200	mA
Pulse Forward current	I _{FP}	240	mA
Power Dissipation	P _D	1320	mW
Reverse Voltage	V _R	5	V
Operating Temperature	Topr	-40~+85	°C
Storage Temperature	Tstg	-40~+100	°C
Junction Temperature	Tj	120	°C
Soldering Temperature	Tsld	Reflow Soldering: 230°C or 260°C for 10sec	

* I_{FP} condition with Pulse: Width≤100μs, Duty cycle≤1/10.

* LED's properties might be different from suggested values like above and below tables if operation condition will be exceeded our parameter range. Care is to be taken that power dissipation does not exceed the absolute maximum rating of the product.

* All measurements were made under the standardized environment of Lightning LED.

Electrical/Optical Characteristics at Tj=25°C

Item	Symbol	Min	Typ	Max	Unit	Condition
Forward Voltage	V _F	5.8	-	6.6	V	IF=150mA
Reverse Current	I _R	-	-	10	μA	VR=5V
Luminous Flux	Φ _V	100	142		lm	IF=150mA
View Angle	2θ _{1/2}	-	120	-	°	IF=150mA
Correlated Color Temperature	CCT	2700	4000	6500	K	IF=150mA
Color Rendering Index	Ra	70	80		-	IF=150mA
Color Rendering Index	R9	-	-	-	-	IF=150mA
Characteristics Coordinates	X	-	0.3875	-	-	IF=150mA
	y	-	0.3868	-	-	IF=150mA
Thermal resistance	(R _{th j-sp})	-	14	-	°C/W	IF=150mA
Electrostatic Discharge	ESD	1000	-	-	V	HBM

* Tolerance of measurements of the Forward Voltage is ±0.2V.

* Tolerance of measurements of the Luminous Flux is ±7%.

* 2θ_{1/2} is the off-axis where the luminous intensity is 1/2 of the peak intensity.

* Correlated Color Temperature is derived from the CIE 1931 Chromaticity diagram.

* Ra measurement tolerance is ±2.

* R9 measurement tolerance is ±6.5.

* Tolerance of measurements of the chromaticity Coordinate is ±0.005.

* R_{th j-sp} is the thermal resistance from LED junction to solder point on MCPCB with electrical power.

Bin Structure

Luminous Flux Ranks, IF = 150 mA, Tj=25°C

CCT	Color Rendering		Luminous Flux		
	Min.	Typ.	Code	Min	Max
2700K	70	72	5K	125	130
			5L	130	135
			5M	135	140
	80	82	5J	120	125
			5K	125	130
			5L	130	135
	90	92	5E	100	105
			5F	105	110
			5G	110	115
3000K	70	72	5M	135	140
			5N	140	145
			5P	145	150
	80	82	5K	125	130
			5L	130	135
			5M	135	140
	90	92	5F	105	110
			5G	110	115
			5H	115	120
4000K	70	72	5N	140	145
			5P	145	150
			5R	150	155
5000K	80	82	5M	135	140
			5N	140	145
5700K	90	92	5P	145	150
5G			110	115	
6500K	90	92	5H	115	120
			5J	120	125

* Tolerance of measurements of the Luminous Flux is $\pm 7\%$.

* Ra measurement tolerance is ± 2 .

Forward Voltage Ranks, $I_F = 150\text{mA}$, $T_j = 25^\circ\text{C}$

Code	Min	Max	Unit
A4	5.8	6.0	V
B4	6.0	6.2	V
C4	6.2	6.4	V
D4	6.4	6.6	V

* Tolerance of measurements of the Forward Voltage is $\pm 0.2\text{V}$.

CIE Chromaticity Diagram, $I_F = 150\text{mA}$, $T_j = 25^\circ\text{C}$

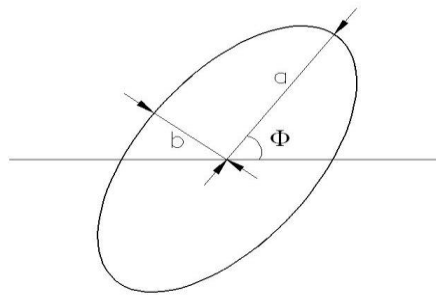

The color ranks have chromaticity ranges within 5-step MacAdam ellipse

Color Code	Center		Radius		Angle(deg)
	x	y	a	b	Φ
27R5	0.4620	0.4145	0.013500	0.00700	53.42
30R5	0.4383	0.4081	0.013900	0.00680	53.13
40R5	0.3875	0.3868	0.015650	0.00670	53.43
50R5	0.3507	0.3635	0.013700	0.00590	59.37
57R5	0.3348	0.3491	0.011175	0.00550	58.35
65R5	0.3187	0.3363	0.011150	0.00475	58.34

* Energy Star binning applied to all 2600~7000K.

* Tolerance of measurements of the chromaticity Coordinate is ± 0.005 .

Fig 1. Color Spectrum, $T_j = 25^\circ\text{C}$

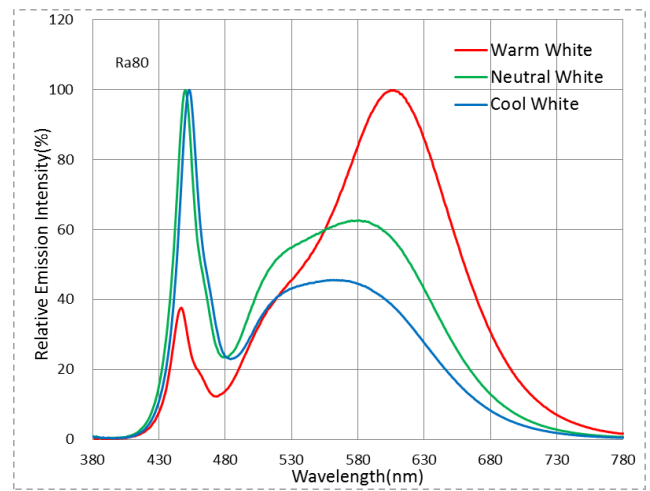
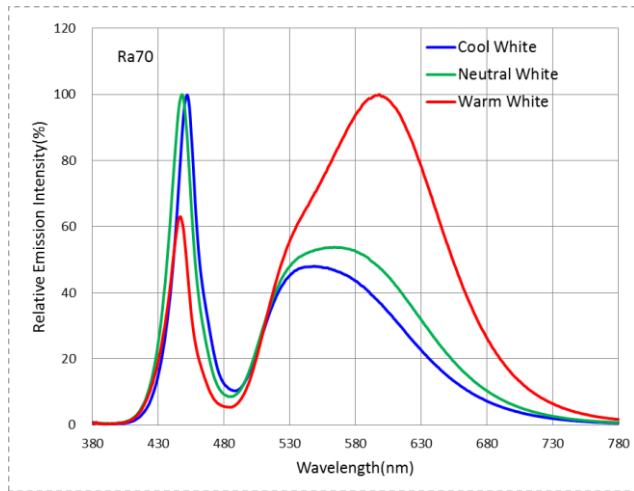

Fig 2. Viewing Angle Distribution, $T_j = 25^\circ\text{C}$

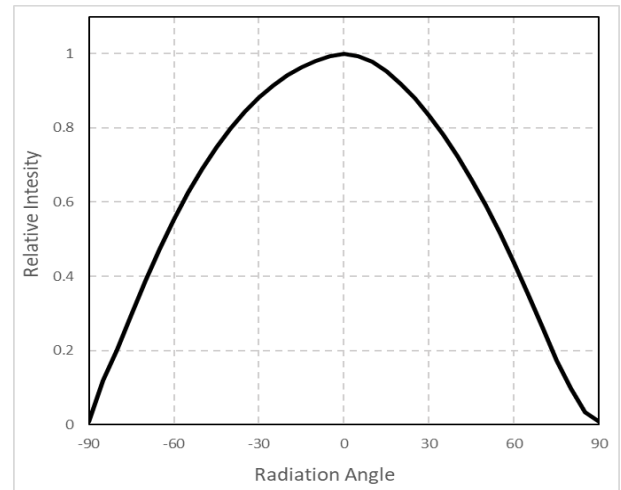
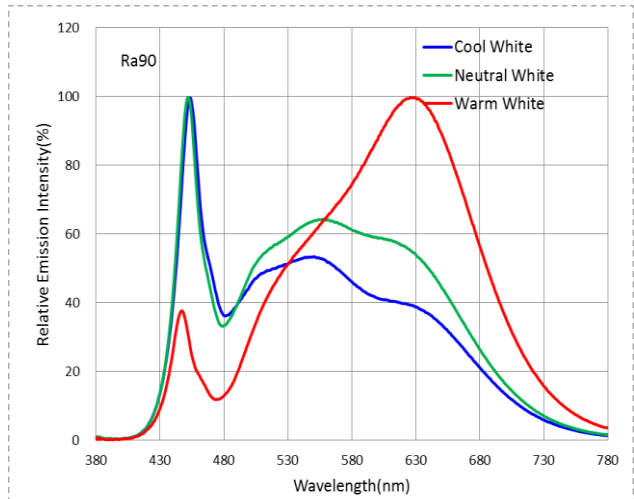

Fig 3. Forward Current vs. Relative Intensity, $T_j = 25^\circ\text{C}$

Fig 4. Forward Current vs. Forward Voltage, $T_j = 25^\circ\text{C}$

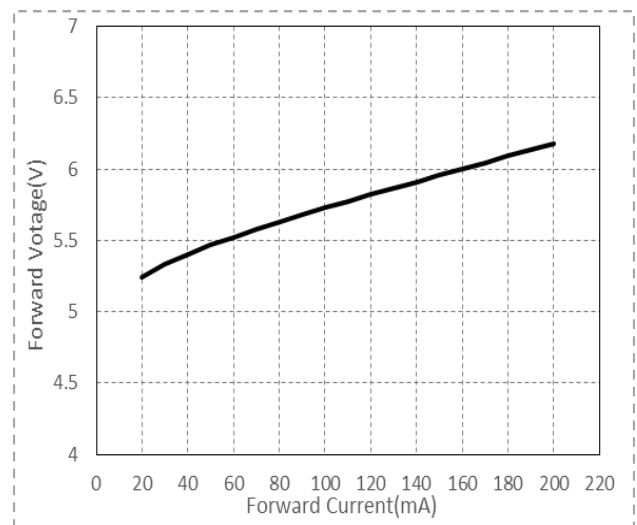
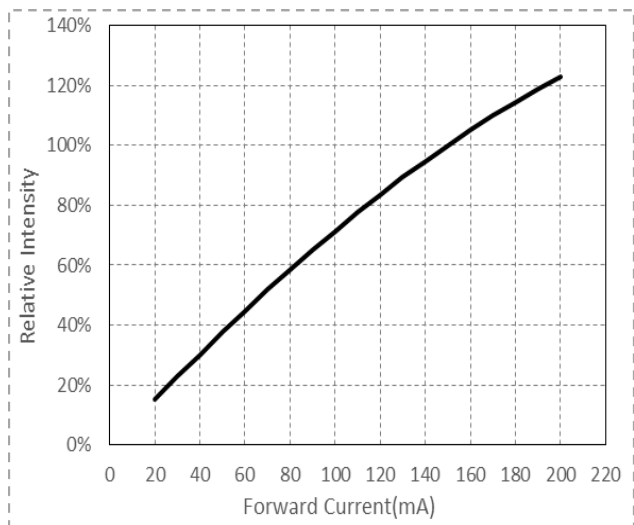

Fig 5. Soldering Temperature vs. Relative Luminous flux (IF=150mA)

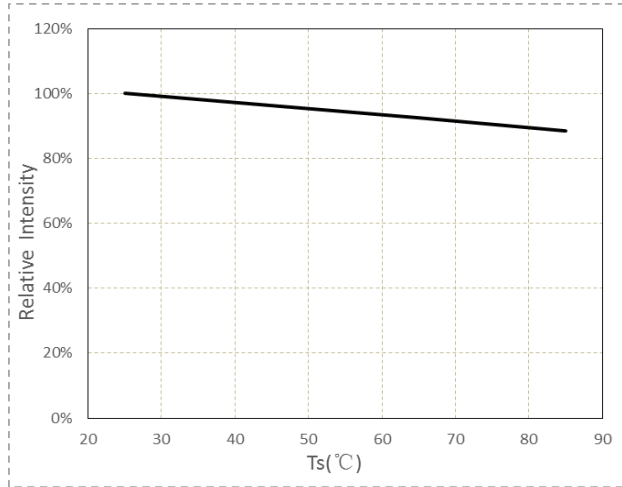

Fig 6. Soldering Temperature vs. Relative Forward Voltage (IF=150mA)

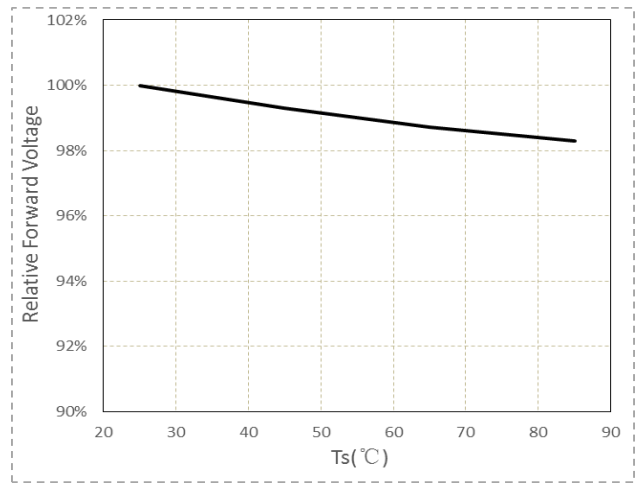
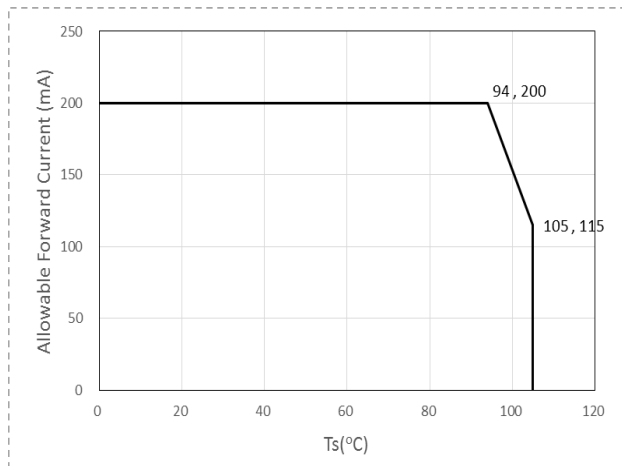
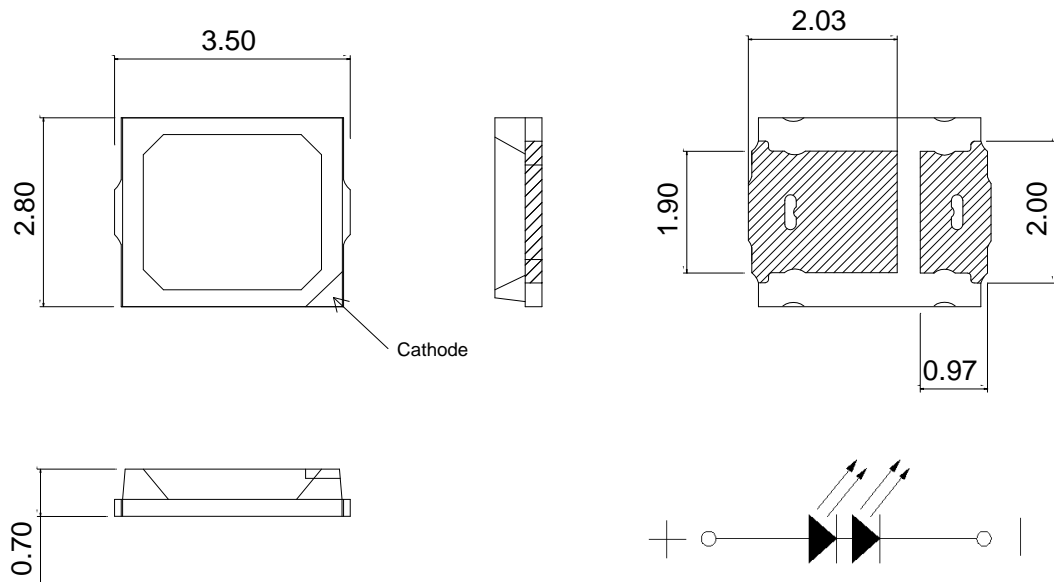

Fig 7. Allowable Forward Current vs. Soldering Temperature

Junction Temperature < 120°C



Package Dimensions



* The tolerance unless mentioned is $\pm 0.1\text{mm}$, unit = mm

Reflow Soldering Characteristics

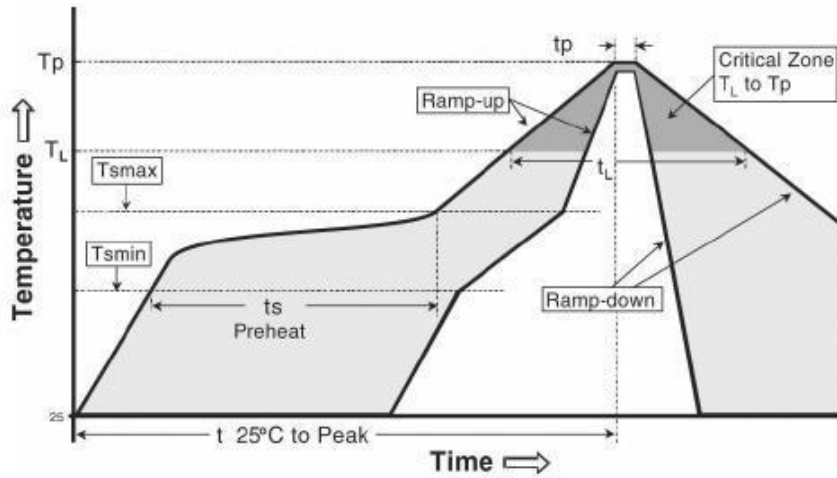

Reflow soldering	
Temperature Min (T_{smin})	150° C
Temperature Max (T_{smax})	200° C
Time(t_s)from (T_{smin} to T_{smax})	60-120 seconds.
Ramp-up rate (T_L to T_p)	3° C/seconds max.
Liquidous temperature(T_L)	217° C
Time(t_L) maintained above T_L	60-150 seconds
Peak package body temperature(T_p)	260° C max
Time (t_p) within 5°C of the specified classification temperature (T_c).	30 seconds max
Ramp-down rate (T_p to T_L)	6° C/second max
Time 25°C to peak temperature	8 min max

Package Dimensions of Tape

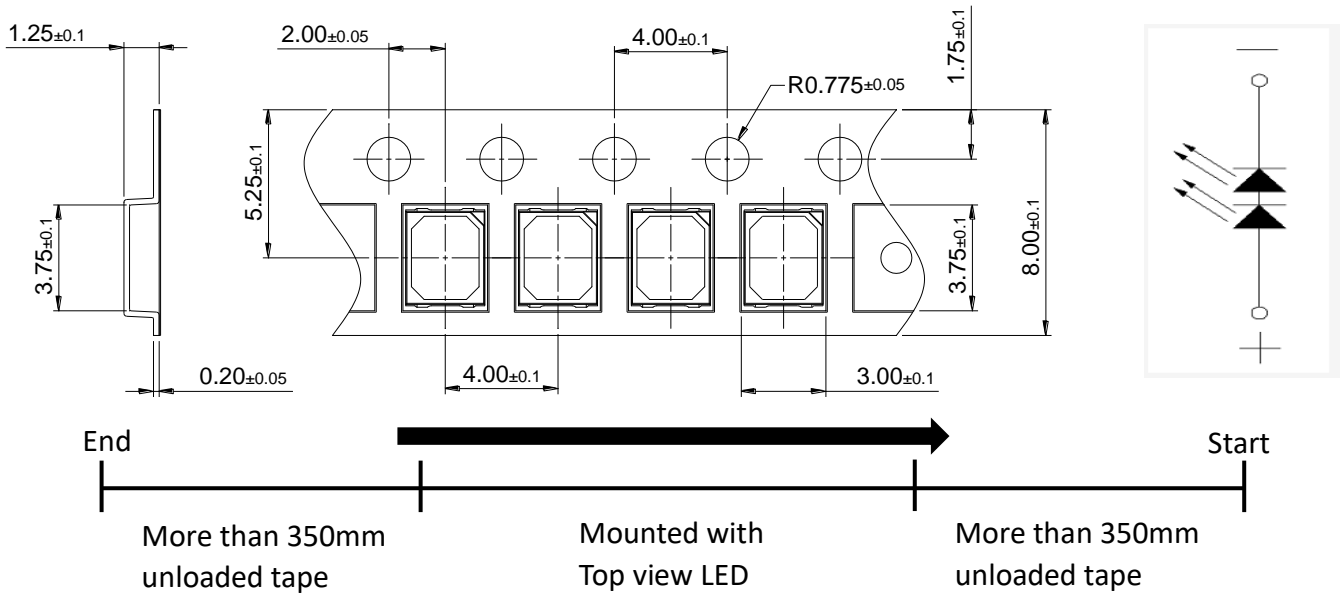

- * Quantity : Max 18000pcs/Reel
- * Cumulative Tolerance : Cumulative Tolerance/10 pitches to be ± 0.2 mm
- * Package : P/N, Manufacturing data Code No. and Quantity to be indicated on a damp proof Package.
- * unit = mm

Package Dimensions of Reel

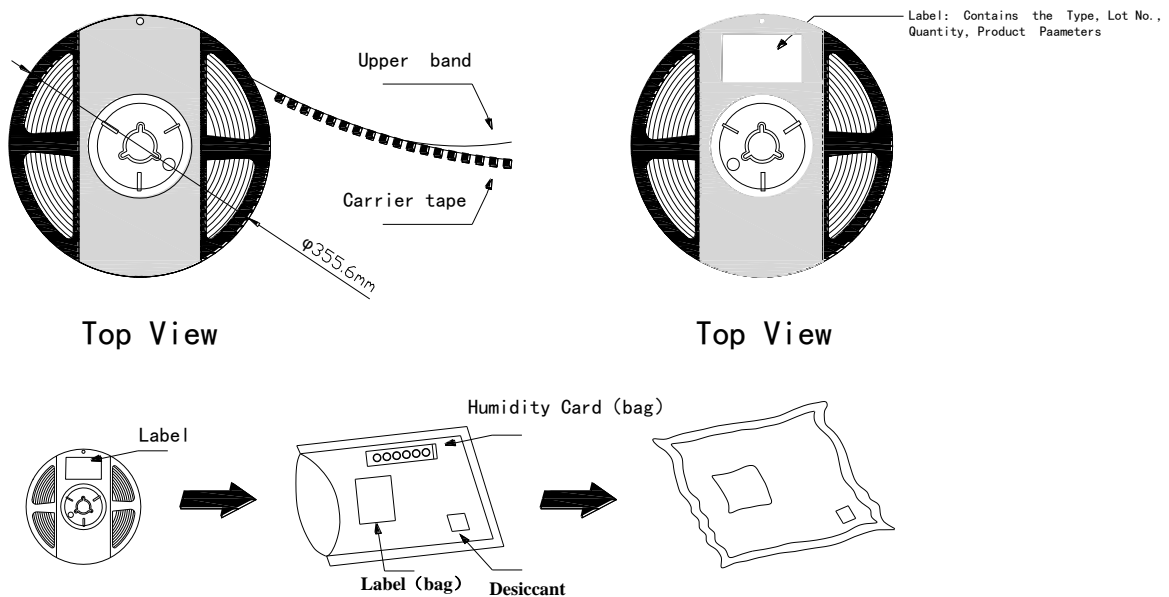

Package Box

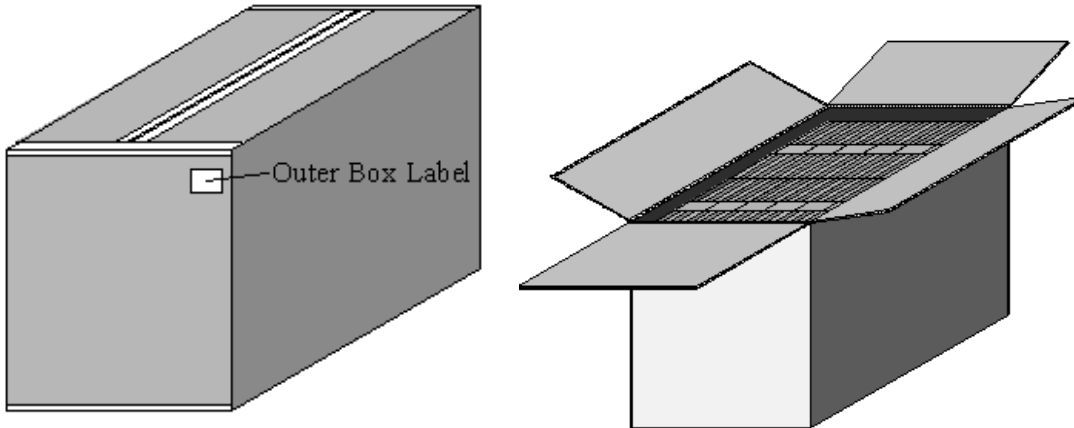

- Capacity 10 reels per box (外箱容量: 10 卷)

Label

福建天电光电有限公司	
FUJIAN LIGHTNING OPTOELECTRONIC CO.LTD	
型号Type: T*****_*****	
	
光通量 Φ @ *** mA: *** - *** [LM]	
色区Color Bin@*** mA: ****	
电压Vf@ *** mA: ** - ** [V]	
显指Ra@*** mA: ** (MIN)	
Lot No.: A*****_*_*****	
Bin Code: ****	数量QTY:**** PCS



Caution

1. Reflow soldering is recommended not to be done more than two times. In the case of more than 24 hours passed soldering after first, LEDs will be damaged.
2. Repairs should not be done after the LEDs have been soldered. When repair is unavoidable, suitable tools must be used.
3. Die slug is to be soldered.
4. When soldering, do not put stress on the LEDs during heating.
5. After soldering, do not warp the circuit board.

Notes on Lightning PCT Series soldering:

1. Recommend to use reflow machine.
2. Recommend to use heating plate soldering.
3. Manual soldering is not recommended.

Notes on reflow process:

1. To confirm whether the actual temperature curve in the reflow soldering conditions comply with recommended conditions. LEDs are guaranteed for one time reflow.
2. During reflow process do not apply force on LED active area.
3. After reflow process, PCB board should be cooled down before packing or storage.

Precaution for use

Storage

1. Before opening the package: The LED should be kept at 5°C~30°C and 60%RH or less.
2. After opening the package: The LED's floor life is 168Hrs under 30°C or less and 60%RH or less. If unused LED remain, it should be stored in moisture proof packages JEDEC (MSL 3).
3. If the moisture absorbent material (silica gel) has faded away or the LEDs have exceeded the storage time, baking treatment should be performed using the following conditions:
Baking treatment: 60±5°C for 24 hours.